

KANE510

Portable Oxygen Analyser



Stock No: 19673

April 2016

© Kane International Ltd

CONTENTS

	Page No:
OWNERS MANUAL & MAINTENANCE	3
1. GETTING STARTED	5
1.1 SAFETY NOTES	5
1.2 PRE-TEST CHECKLIST	5
1.3 ANALYSER CONNECTIONS	6
1.4 POST TEST	6
2. MAINTENANCE	6
2.1 GENERAL MAINTENANCE	6
2.2 PERIODIC SERVICE	6
2.3 ANNUAL RE-CALIBRATION	7
2.4 CLEANING	7
2.5 EMPTYING AND CLEANING THE IN-LINE WATER TRAP	7
2.6 CHANGING THE PARTICLE FILTER	7
2.7 BATTERIES REPLACEMENT	8
3. ANALYSER PROBLEM SOLVING	9
4. ANALYSER SPECIFICATION	10
5. CLEANING	11
6. ANNUAL RECALIBRATION AND SERVICE	11
6.1 RETURNING YOUR ANALYSER TO KANE	12
6.2 SERVICE RETURNS	13
7. ELECTROMAGNETIC COMPATIBILITY	15
8. END OF LIFE DISPOSAL	16
PRODUCT REGISTRATION	17-18

OWNERS MANUAL & MAINTENANCE

The KANE510 is a portable Oxygen (O₂) Gas Analyser and is suitable for any application requiring the accurate measurement of oxygen levels. Typical applications include, welding gases, controlled atmosphere rooms, fermentation and fruit storage areas.

It uses an electro-chemical sensor with a typical life expectancy of 7 years to measure Oxygen.

The analyser is controlled using a rotary dial.

The dial positions are:

OFF	Turn unit off
O ₂	Measure O ₂ %
CO ₂ %	Display calculated CO ₂ , calculated value will only be shown if O ₂ reading is less than 18% Depending on fuel type selected.
Eff %	Display Calculated Efficiency, temperature probe must be connected and O ₂ must be less than 18%
T Flue	Measure Temperature °C
Fuel	Select desired fuel type

Intelligent Startup

Rotary Dial

When transitioning from "OFF" to any position the pump will switch on and display model, version, currently selected fuel type, the user selected mode and then the remainder of the 30s air purge (except the Fuel position will immediately show the fuel list).

When transitioning from any other position the KANE510 will display the selected mode and fuel type on the display for 0.5 seconds each before showing live readings.

Fuel Selection

Move the dial to the Fuel position, each of the user selectable fuels will be displayed for 2 seconds, when the desired fuel is displayed move the rotary dial back to a measurement position and the fuel will now be stored until changed by the user.

Stored Inlet Temperature

If the probe & thermocouple are connected during the fresh air purge the temperature will be stored as the inlet temperature. This will be indicated by #.

This stored value will be cleared when the analyser is turned off. If no probe is connected at turn ON the subsequent efficiency calculations will be based on the internal temperature of the analyser.

Sensor

The O₂ sensor is permanently powered to maintain its performance, if for any reason power is lost (batteries are flat or removed) the sensor will require a maximum of 1 hour to return to factory performance. To minimize this start up time the KANE510 employs an intelligent start procedure to assess the status of the sensor and decrease the warm up time accordingly (for more information see the Battery Replacement section).

1. GETTING STARTED

1.1 SAFETY NOTES

Before using this analyser, read all safety information carefully. In this manual the word “WARNING” is used to indicate conditions or actions that may pose physical hazards to the user. The word “CAUTION” is used to indicate conditions or actions that may damage this instrument.



WARNING!

This analyser extracts gases that may be toxic in relatively low concentrations. These gases are exhausted from the back of the instrument. This instrument must only be used in well-ventilated locations. It must only be used by trained and competent persons after due considerations of all the potential hazards.

1.2 PRE-TEST CHECKLIST

Clean particle filter

Water trap and probe line are empty of water

Water trap is fitted correctly to the instrument

Temperature plug is connected (optional)

All hose and thermocouple connections are properly secured

Gas probe is sampling ambient FRESH air

Power on and zero

1.3 ANALYSER CONNECTIONS

NOTE: Take care when inserting the temperature probes as the pins are polarized. Insert with the smaller pin into input marked positive. (+)



CAUTION!

Turning the pump off while the probe is in the sampling point for the flue gases will potentially leave toxic gases inside the analyser. When the desired readings have been taken, it is advisable to purge the unit with fresh air as soon as possible. To do this, with the probe removed from the sampling point and the rotary switch in the O₂ measurement position allow the O₂ reading to come back to 20.95% +0.5%.



CAUTION!

The probe could be hot when sampling the flue gases, remove the probe from the sampling point and allow it to cool naturally. Do not immerse the probe in water, as this will be drawn into the analyser and damage the pump and sensor. Once the probe is removed from the sampling point and the readings have returned to ambient levels rotate the selector to “OFF”.

1.4 POST TEST

Remove the probe from the sampling point and allow the analyser to purge with fresh air until the O₂ reading returns to 20.95% +0.5%. (*Be careful as the probe tip could be HOT*)

Drain water trap.

Check particle filter.

2. MAINTENANCE

2.1 GENERAL MAINTENANCE

Check calibration of your analyser annually to ensure it meets original performance specifications.

Keep your analyser dry. If it gets wet, wipe dry immediately. Liquids can degrade electronic circuits.

Whenever practical, keep the analyser away from dust and dirt that can cause premature wear.

Although your analyser is built to withstand the rigours of daily use, it can be damaged by severe impacts. Use reasonable caution when using and storing the analyser.

2.2 PERIODIC SERVICE



CAUTION!

Repair and service of the analyser is to be performed by qualified personnel only. Improper repair or service could result in physical degradation of the analyser. This could alter the protection from personal injury this analyser provides to the operator. Perform only those maintenance tasks that you are qualified to do.

2.3 ANNUAL RE-CALIBRATION

While the sensor used in the analyser has a life expectancy of seven years in normal use it is recommended that the analyser is re-calibrated at least annually, this is so that long-term drift on the electronics can be eliminated. Local regulations may require more frequent re-calibration and users should check with appropriate authorities to ensure they comply with relevant guidelines.

2.4 CLEANING

Periodically clean your analyser case using a damp cloth. DO NOT use abrasive, flammable liquids, cleaning solvents, or strong detergents as they may damage the finish, impair safety, or affect the reliability of the structural components.

2.5 EMPTYING AND CLEANING THE IN-LINE WATER TRAP

The integral water trap should be checked and emptied on a regular basis. Water vapour will condense in the probe line, which may cause the water trap to fill suddenly if the probe is moved. Care should be taken at all times.

Carefully unscrew the plug from the bottom of the water trap housing. Dispose of the condensate in a suitable drain, care must be taken as it could be acidic. If condensate spills onto the skin or clothing, clean off immediately using fresh water, seek medical advice if problems occur. Ensure plug is replaced before performing combustion tests.

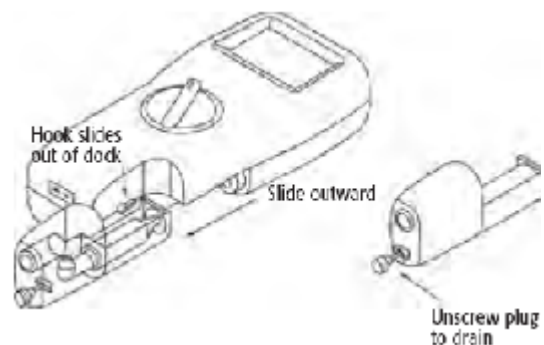

NOTE: O₂ reading will be invalid if the Water Trap Plug is not in place.

2.6 CHANGING THE PARTICLE FILTER

This is a very important part of the analyser and should be changed regularly. It prevents dust and dirt particles from entering pump and sensors that will cause damage. The filter **MUST** be changed when it becomes discoloured.

Remove water-trap assembly from the analyser as shown above. Remove the filter and plastic holder from the housing. Discard the filter element but keep the holder to fit to the new filter. Clean the inside of the filter housing with a suitable soft cloth. Fit the holder onto the new filter element and then insert into the housing. Refit the housing onto the analyser.

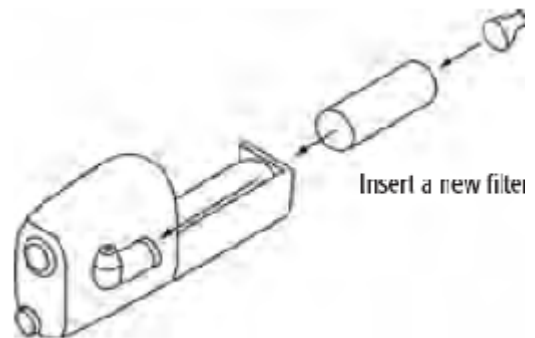

2.7 BATTERIES REPLACEMENT

The analyser has been designed for use with alkaline batteries. No other types are recommended. The analyser is supplied with 4 "AA" size alkaline batteries.

These should be installed into the instrument as shown in the diagram to the right and indicated on the back of the unit.

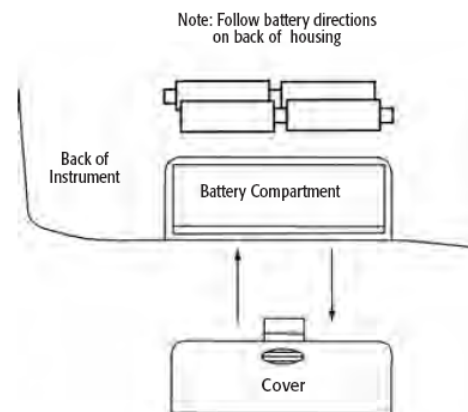

CAUTION!

Take great care when installing the batteries to observe the correct polarity. Always check the analyser for operation immediately after installing new batteries.

Sensor Start up

Once the new batteries are fitted the KANE510 will initially display a 1 hour (displayed in seconds 3600) countdown which will prevent the analyser from being used until the timer has elapsed, however as already mentioned the KANE510 uses an intelligent start up procedure which will reduce the countdown as the sensor returns to factory performance. If the batteries are replaced within 5 to 10 minutes of the old batteries being removed the KANE510 should be ready to use within 5 to 10 minutes.

3. ANALYSER PROBLEM SOLVING

If any problems are not solved with these solutions, contact Kane International Ltd or an authorised repair centre.

Fault Symptom	Causes / Solutions
O ₂ too high	Air leaking into probe, tubing, water trap or connectors.
Analyser does not respond to target gas	Particle filter blocked. Probe or tubing blocked. Pump not working or damaged with contaminants.
Temperature readings erratic	Temperature plug reversed in socket. Faulty connection or break in cable or plug.
T Flue displays (----)	Probe not connected or faulty.
CO ₂ displays (----)	O ₂ is greater than 18%
Eff % displays (----)	O ₂ is greater than 18% or check temperature connection
Flo on display	Possible blockage in water-trap or pump failure, clear blockage move the rotary switch to new position and back to O ₂
Bat on display	Batteries very low instrument has gone into dead battery mode to keep the O ₂ sensor powered as long as possible, replace batteries immediately

4. ANALYSER SPECIFICATION
(NOTE MAY BE SUBJECT TO CHANGE)

Parameter	Resolution	Accuracy	Range
Temperature	0.1 °C	± 0.5°C	0-600°C
Oxygen	0.01%	±0.3%	0 - 25%
Carbon Dioxide(Calculated)	0.01%	±0.3%	0 - 30%
Efficiency(Calculated)	0.01%	±1.0%	0 – 119.9%
Dimensions (approximate) Weight Handset Probe	0.5 Kg 180mm x 85mm x 50mm 250mm x 6mm stainless steel shaft nominal 0.9m neoprene hose.		
Ambient Operating Range	+0°C to 45°C 10% to 90% RH non- condensing 850 to 1100 mbar atmospheric pressure		
Battery Life	4 AA cells >20 (in O2 measurement) hours using Alkaline AA cells 18 Months in"OFF" position		

5. CLEANING

This product can be cleaned using a damp lint free cloth and a small amount of non-abrasive detergent. Take care to avoid moisture entering the sensor's grill and after cleaning leave the product in a warm dry place to allow any surface dampness to evaporate. Under no circumstance should any solvent cleaner be used as this may cause damage to the plastic case, display and sensor.

6. ANALYSER ANNUAL SERVICE & RE-CERTIFY

Although sensor life is typically seven years, the KANE510 should be serviced and re-certified annually to counter any long-term sensor or electronics drift or accidental damage.

Local regulations may require more frequent re-certification.

By returning your analyser back to Kane for an annual fixed price service (check www.kane.co.uk for details) you have the opportunity to extend the warranty on your analyser to 5 years.

6.1 RETURNING YOUR ANALYSER TO KANE

When returning your KANE510, please always ensure that you enclose:

- ✓ Your full contact details
- ✓ A daytime telephone number
- ✓ Details of faults you might have experienced

Packing your analyser

When returning your analyser, please pack it appropriately to prevent any damage during transit.

Before sealing your package, please ensure that you have enclosed the items listed above and that it is clearly marked for the attention of:

Southern Service Centre
Kane International Ltd
Kane House, Swallowfield
Welwyn Garden City
Hertfordshire
AL7 1JG

Northern Service Centre
Kane International Ltd
Gibfield Park Avenue
Atherton
Manchester
M46 0SY

Sending your analyser

Once the analyser has been securely packed then your package is ready for shipment back to Kane. If you do not have an account with a courier company you can take your package to your local Post Office. It is advisable to send the package by Special Delivery so that it is insured and traceable while in transit.

When we receive your analyser

On receipt of your package, our Service Engineers will inspect the analyser and any accessories and confirm to you the total service cost. Once you have accepted this the work will be carried out, and upon completion the analyser returned to you.

If you have any questions that we haven't answered, please feel free to contact your local Service Centre:

SALE AND SUPPORT BY:

NEVCO 

Excellence in Measurements...

 +91-11-41717112 / 13 / 14 / 15

 sales@nevcoengineers.com